

Bitte lies dir diese Anleitung unbedingt vor dem Aufbau komplett durch.

Aufbauanleitung

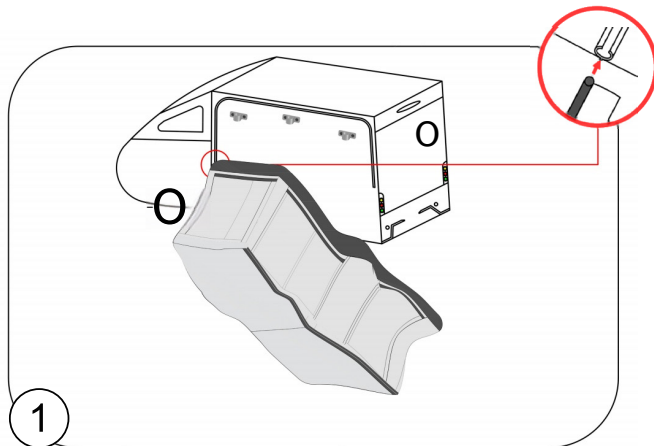

① Schiebe den Keder in die Schiene.

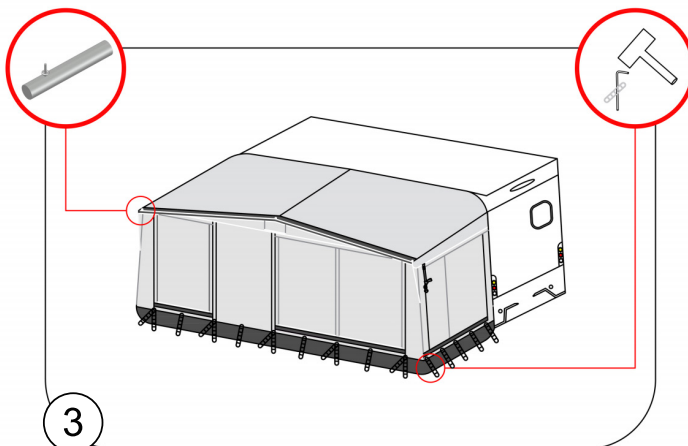

③ Richte das Vorzelt aus und spanne es ab.

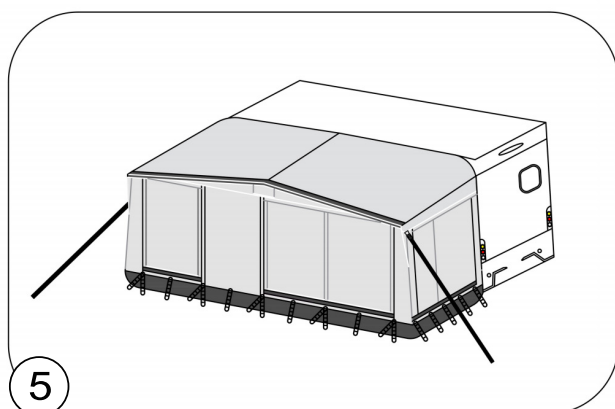

⑤ Fertig

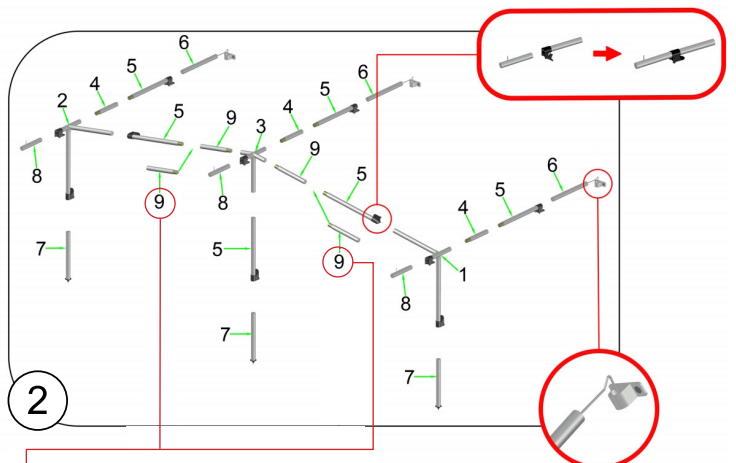

② Montiere das Gestängeset in der richtigen Größe, um das Vorzelt aufzustellen.

- 630601910-6306011000: Setze an beiden Seiten die Stahlstange an Nr. 9 ein.
- 6306011030-6306011090: Setze an beiden Seiten zwei Stahlstangen an Nr. 9 hinzu.

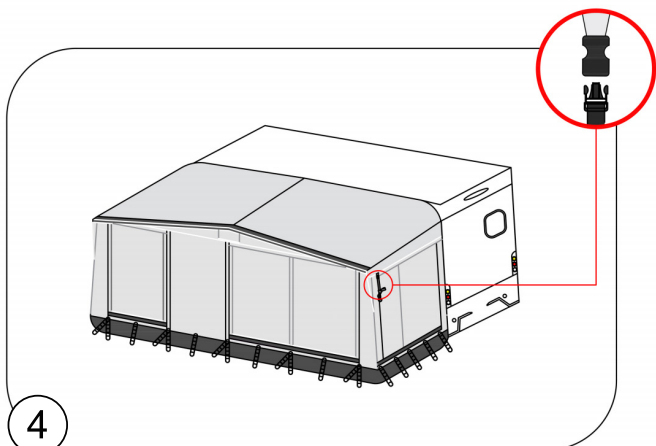

④ Verstärke die Konstruktion mit dem optionalen Sturmband-Set.

Campione Pro

Nr. 630601910 | Nr. 630601940 | Nr. 630601970 | Nr. 630 6011000 |
 Nr. 6306011030 | Nr. 6306011060 | Nr. 6306011090

Important! Please read carefully and keep it for future reference!

Instruction Manual

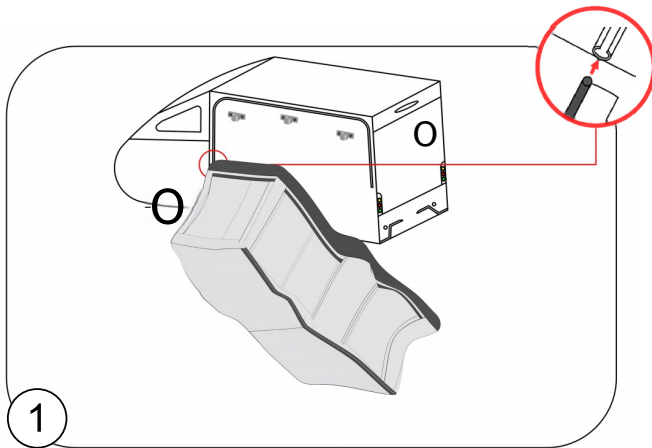

① Slide the keder into the rail.

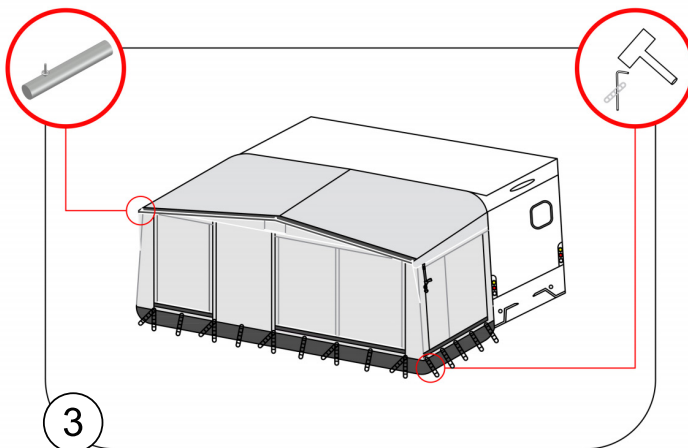

③ Align the awning and tension it.

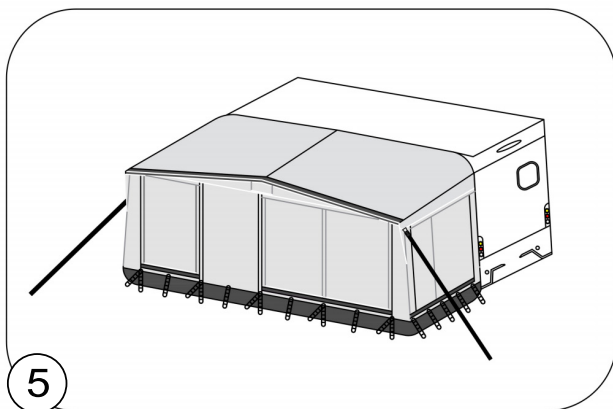

⑤ Completion.

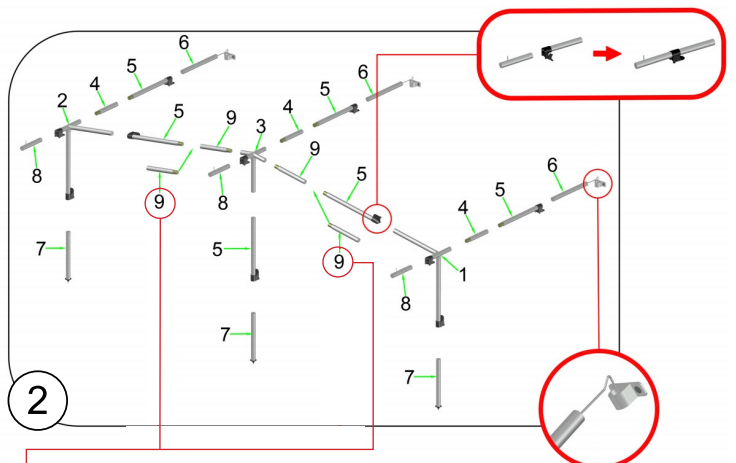

② Assemble the pole set in the correct size to set up the awning.

- 630601910-6306011000: Add a steel pole in NO. 9 to both sides.
- 6306011030-6306011090: Add 2 steel poles in NO. 9 to both sides.

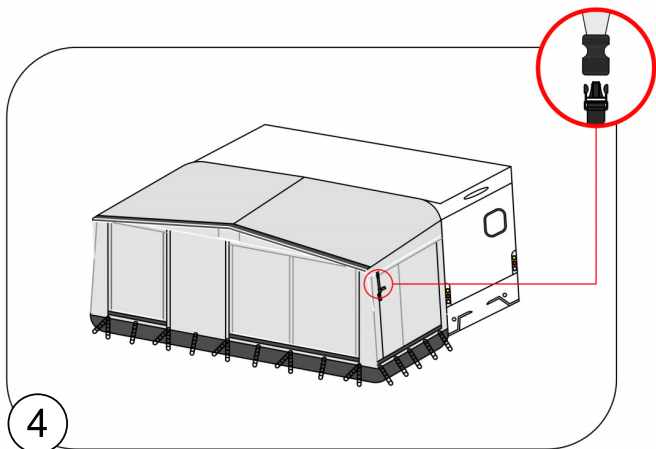

④ Reinforce the structure with the optional storm strap set.

Important ! Veuillez le lire attentivement et le conserver pour référence future !

Instructions de montage

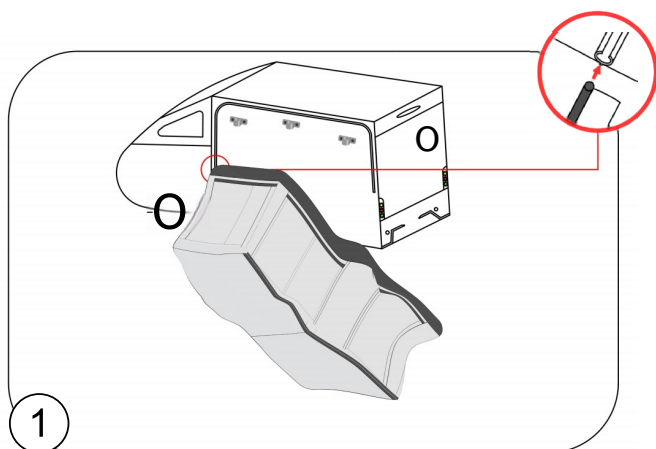

① Insérez le bourrelet dans le rail.

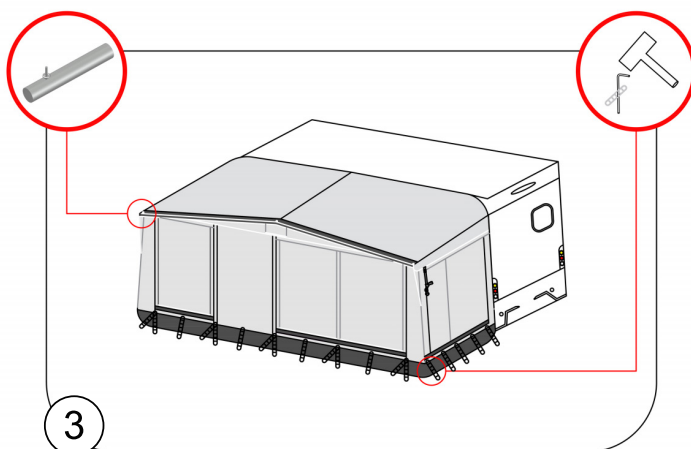

③ Alignez l'auvent et tendez-le.

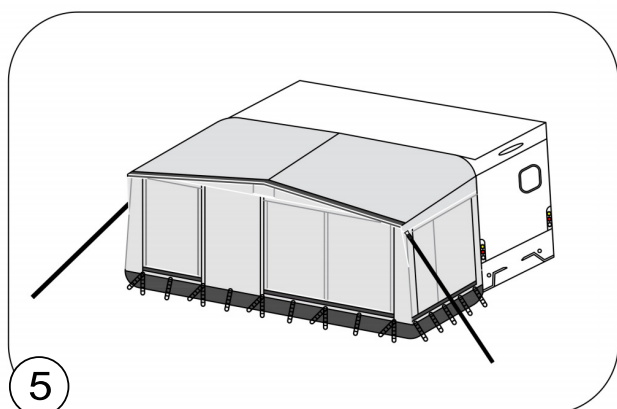

⑤ Terminé

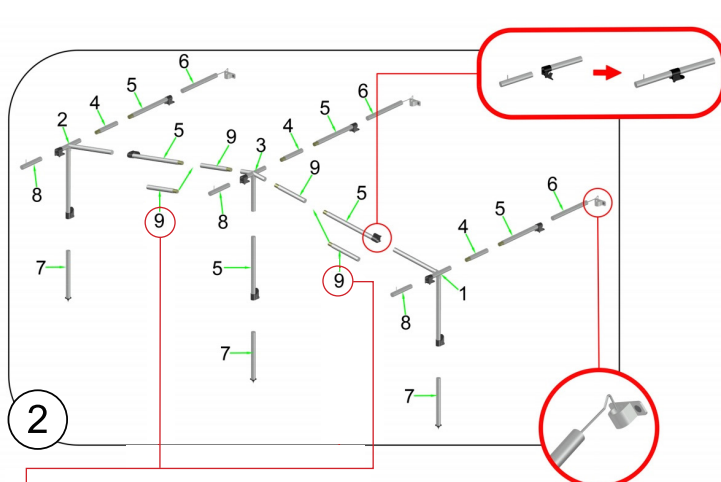

② Montez le kit d'armature de la bonne taille pour installer l'auvent.

- 630601910-6306011000 : insérez la tige en acier n° 9 des deux côtés.
- 6306011030-6306011090 : ajoutez deux barres en acier au n° 9 des deux côtés.

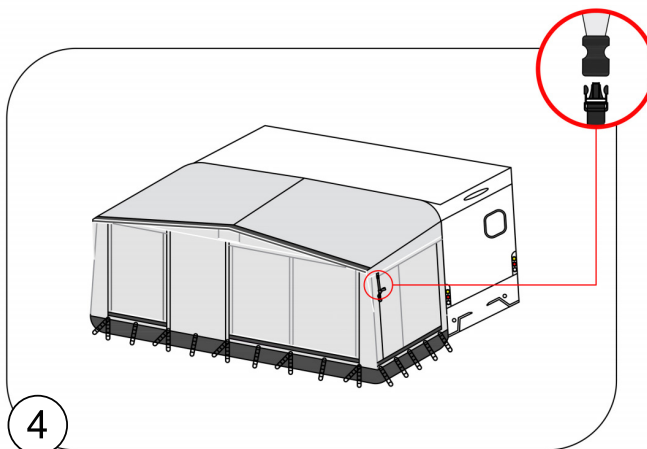

④ Renforcez la structure à l'aide du kit de sangles anti-tempête en option.

Campione Pro

Nr. 630601910 | Nr. 630601940 | Nr. 630601970 | Nr. 630 6011000 |
 Nr. 6306011030 | Nr. 6306011060 | Nr. 6306011090

Importante! Si prega di leggere attentamente e di conservarlo per riferimento futuro!

Istruzioni per il montaggio

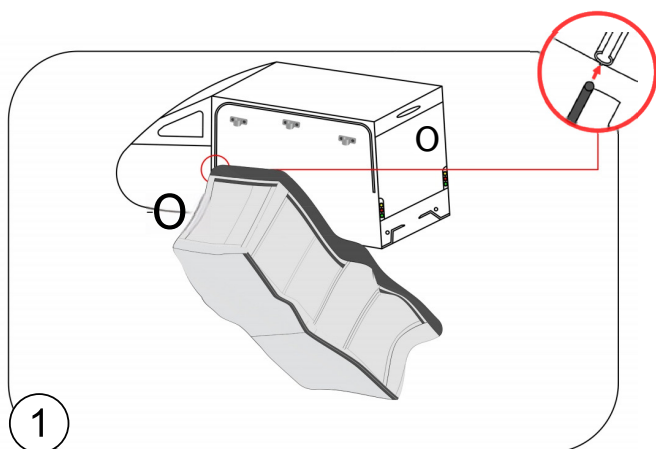

① Inserisci il cordone nella guida.

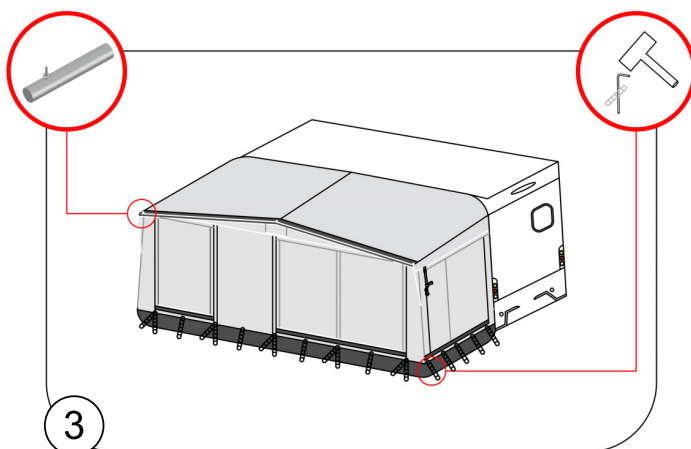

③ Allineare la veranda e tenderla.

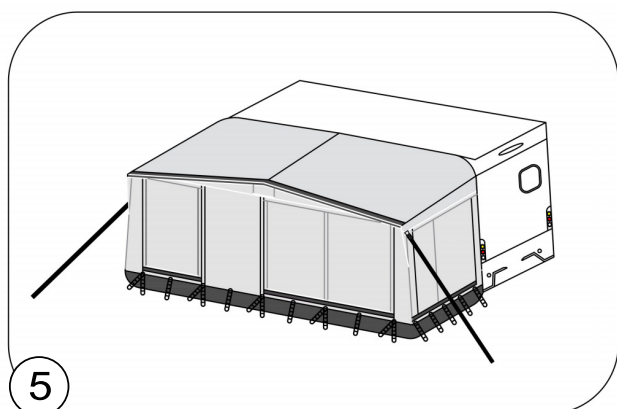

⑤ Fatto

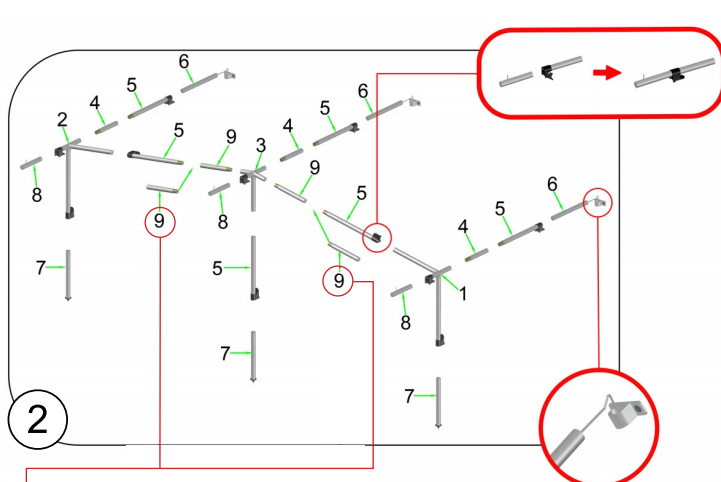

② Montare il set di aste della dimensione corretta per aprire la veranda.
 — 630601910-6306011000: inserisci l'asta in acciaio su entrambi i lati al n. 9.
 — 6306011030-6306011090: inserisci due barre in acciaio su entrambi i lati al n. 9.

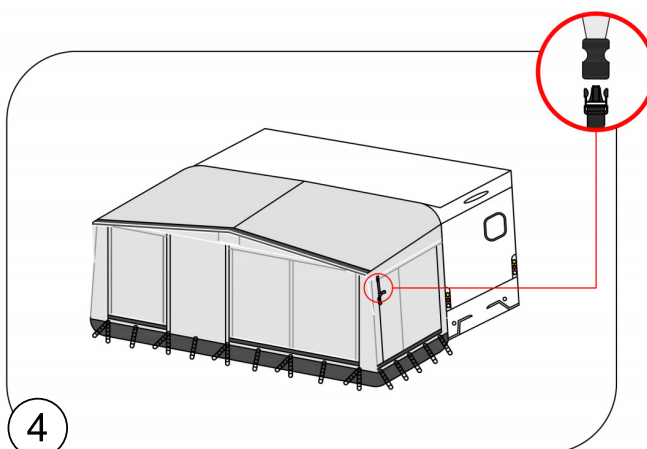

④ Rinforzare la struttura con il set di cinghie anti-tempesta opzionale.

Campione Pro

Nr. 630601910 | Nr. 630601940 | Nr. 630601970 | Nr. 630 6011000 |
 Nr. 6306011030 | Nr. 6306011060 | Nr. 6306011090

Lees het zorgvuldig en bewaar het voor toekomstige referentie!

Montagehandleiding

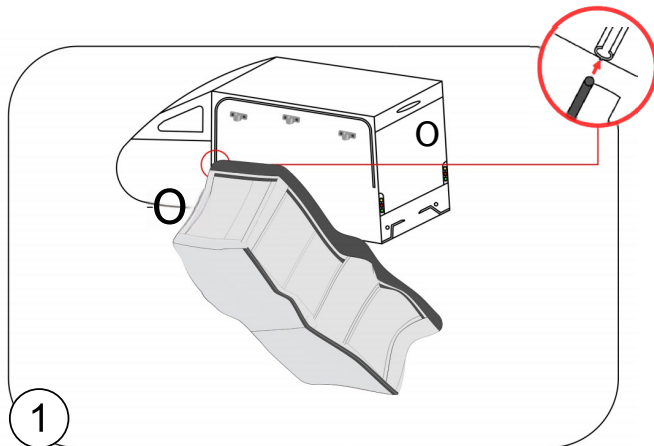

① Schuif de keder in de rail.

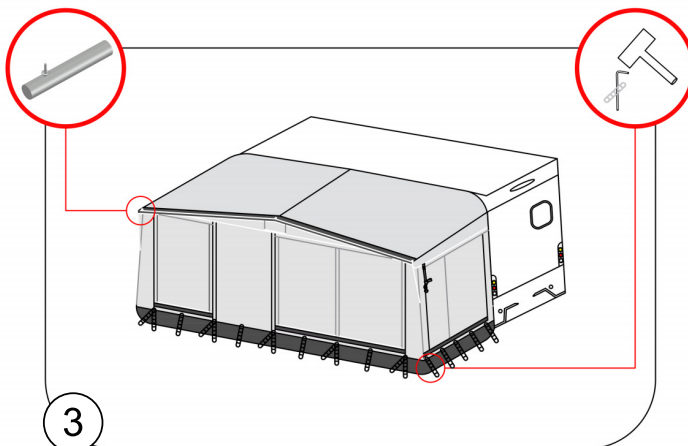

③ Zet de voortent recht en span hem op.

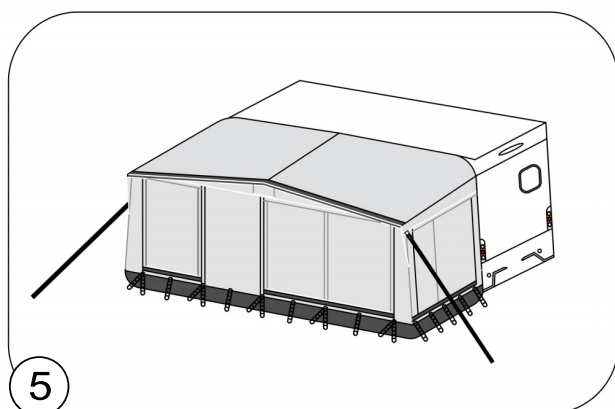

⑤ Klaar

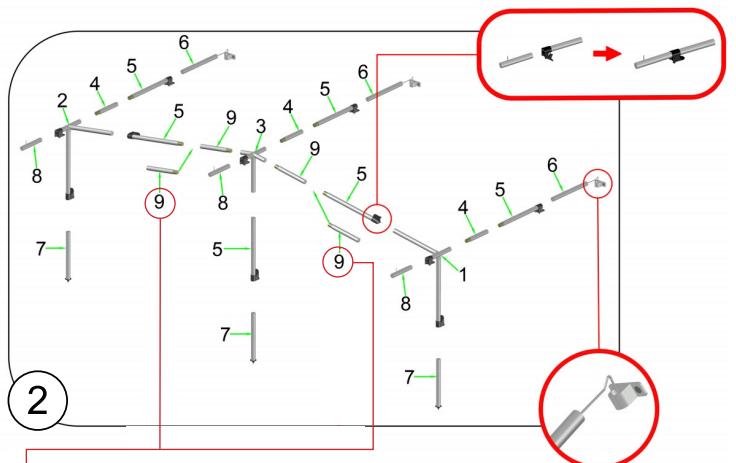

② Monteer de stokken in de juiste maat om de voortent op te zetten.

- 630601910-6306011000: Plaats aan beide zijden de stalen stang bij nr. 9.
- 6306011030-6306011090: Plaats aan beide zijden twee stalen stangen op nr. 9.

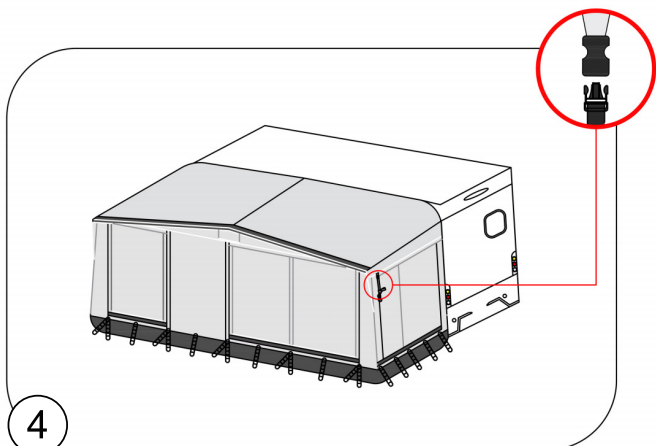

④ Versterk de constructie met de optionele stormbandenset.