

ArmaComfort[®]

Our new ArmaComfort Barrier products significantly reduce disturbing noise to provide environmentally friendly, sound attenuation – halogen- and bitumen-free. Based on a unique eva/epm blend, ArmaComfort Barrier offers an ideal combination of technical and mechanical properties and are easy to install. **Install it. Enjoy the silence**

www.armacell.com





UP TO
-30dB
WITH JUST
3 mm

About ArmaComfort Barrier

ArmaComfort Barrier products are high-performance flexible sound protection solutions engineered for an excellent reduction of airborne transmission in internal applications.

The ArmaComfort Barrier product range consists of ArmaComfort Barrier P (pearly-white), ArmaComfort Barrier B (black) and ArmaComfort Barrier B-Alu (aluminium finish).



Sound pressure level of common environmental sounds (dB)

Contents

General

- 04 Working with ArmaComfort Barrier
- 05 Tools for installing ArmaComfort Barrier

Application

- 06 Flat surfaces
- 07 Wall partitions
- 08 Rectangular ducts
- 09 Round ducts
- 10 90° bend application
- 16 T-piece application
- 18 Ceiling Plenums

FLEXIBLE,
BENDABLE,
EASY TO CUT

WORKING WITH ARMACOMFORT BARRIER

- // ArmaComfort Barrier self-adhesive can be applied on the most common types of substrate (gypsum board, metal and pressed wood) following the recommendations in this application manual. Other substrates must be tested before application.
- // The installer should have a general knowledge of the installation techniques for heavy barrier acoustic insulation.
- // Use high-quality tools.
- // Use clean ArmaComfort Barrier material and avoid installing at temperatures below +10° C and humidities above 70 %.
- // To ensure a strong bond with ArmaComfort Barrier, the substrate must be smooth, solid, clean and dry. There should be no debris, rust, dust, dirt, oil or similar contamination. If necessary, apply ArmaFlex Cleaner to the surface of the substrate prior to the application. The substrate must be free of any elements that could damage the membrane.
- // In order to prevent air bubbles while applying ArmaComfort Barrier use firm pressure, always bonding away from the starting point.
- // Do not carry out fabrication on the floor. Always use a clean workbench when working with ArmaComfort Barrier products.
- // ArmaComfort Barrier products can be cut easily using a sharp craft knife. Such knives should be handled with due care.

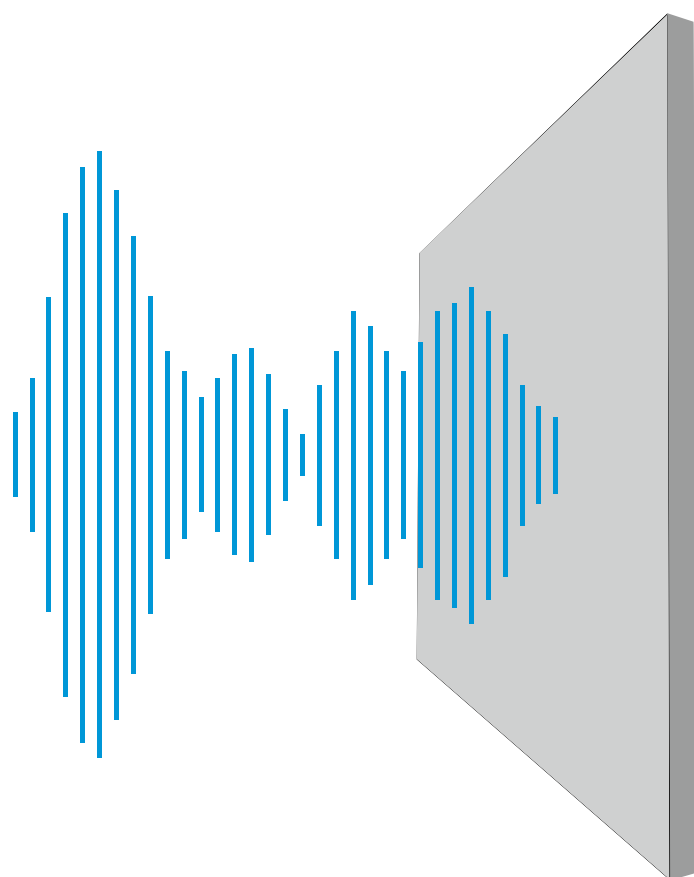

SOUND TRANSMISSION LOSS

A material's noise reduction performance can be defined as its ability to reduce the sound passing through it. The key value is the Weighted Sound Reduction Index (Rw in dB). It is a single number rating of airborne sound insulation between rooms, over a range of frequencies. The denser and more impervious a material, the better it blocks or reduces sound transmission from one room to another.

TOOLS FOR INSTALLING

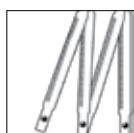

**Folding rule/
tape measure**

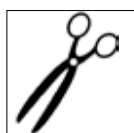

Scissors

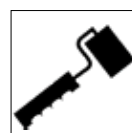

**Seam
roll**



**Chalk for marking
irregular shapes**



**Sharpened pipe ends
for the most common
pipe diameters**

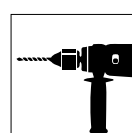

Drill



**Marker
pen**

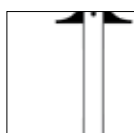

**Straight edge/
ruler**

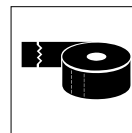

**Alu
tape**



Dividers



**Metal
band**

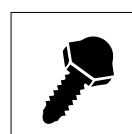

**Screws with
neoprene
moulded seal**



Callipers



**ArmaFlex
Toolbox**

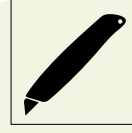

**Craft
knife**

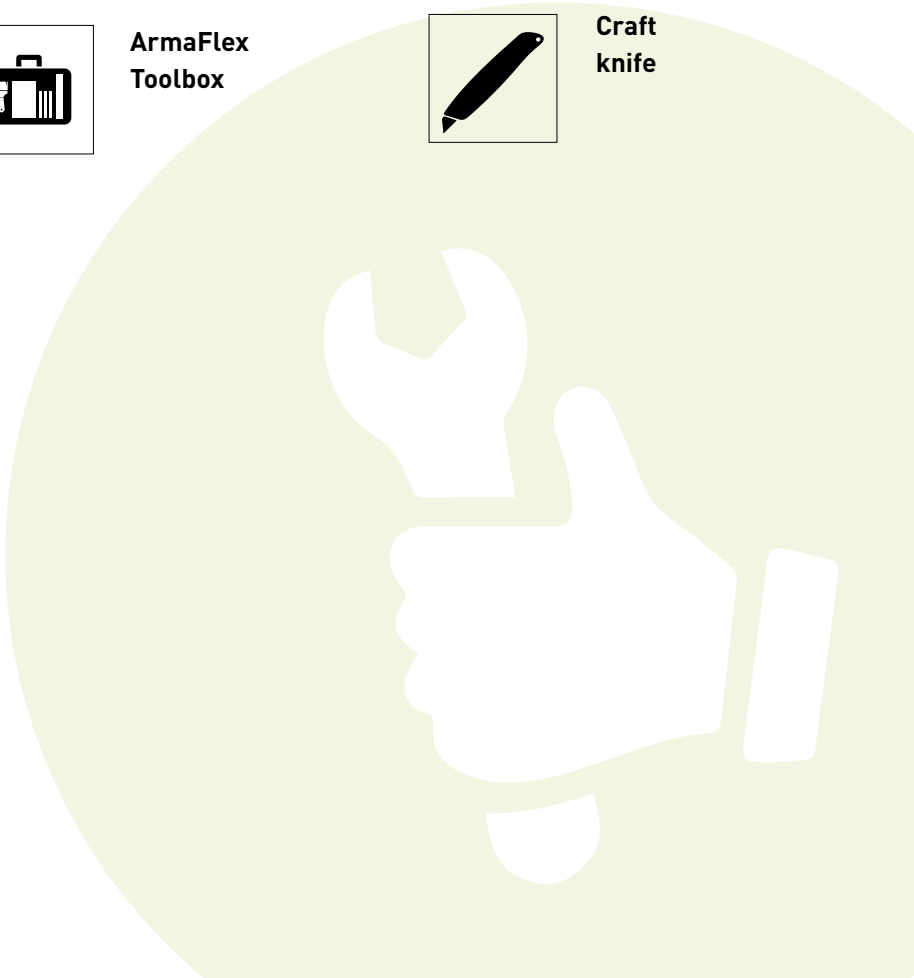

FLAT SURFACES

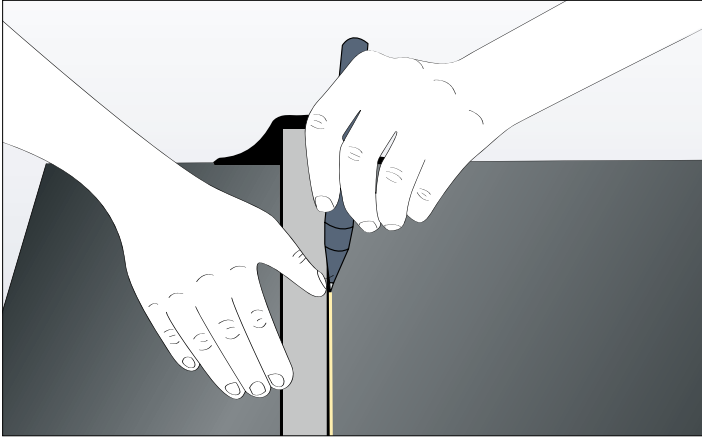

Picture 1

- 1) Before cutting, measure the dimensions accurately and transfer them onto the surface of the ArmaComfort Barrier using a pencil and a ruler or straight edge (see Picture 1).

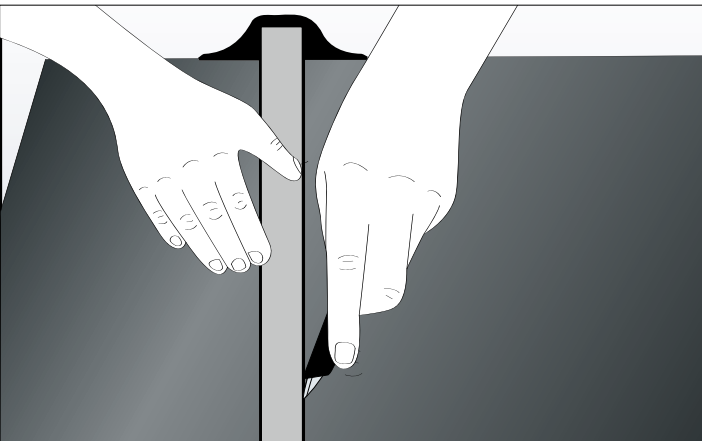

Picture 2

- 2) Only use a craft knife to cut ArmaComfort Barrier. Always use a ruler or straight edge to ensure a linear cut and avoid gaps in the installation (see Picture 2).

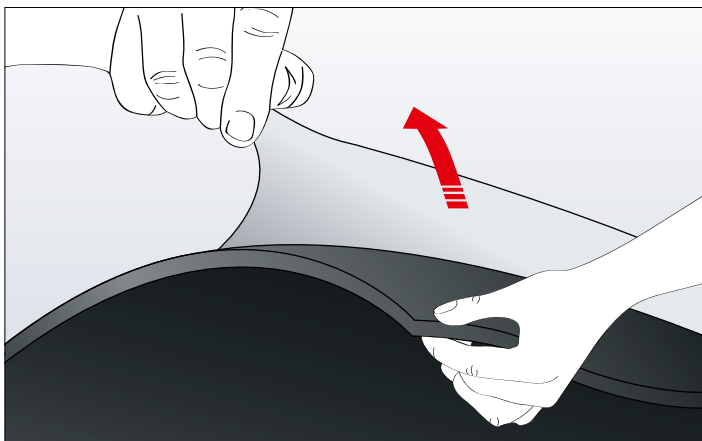

Picture 3

- 3) On flat surfaces, ArmaComfort Barrier must be bonded onto the application surface thoroughly and homogeneously to achieve complete adhesion without any air bubbles between substrate and material.

- 3.1) Peel back 10 to 20 cm of the protective foil and position the ArmaComfort Barrier (see Picture 3).

Note: Before applying ArmaComfort Barrier, make sure that the application surface is free of residues. If necessary use ArmaFlex Cleaner.

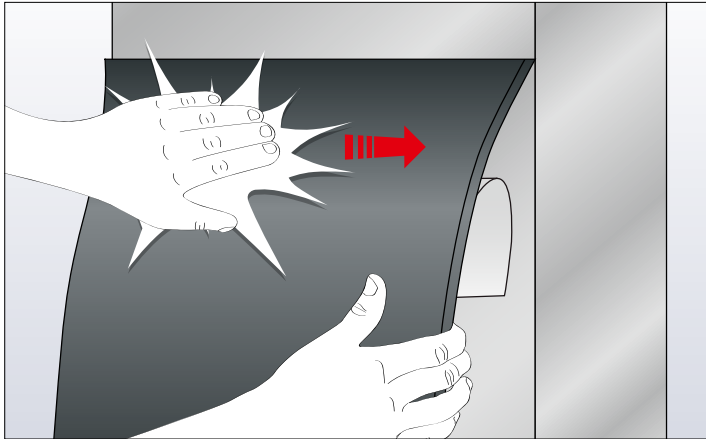

Picture 4

3.2) Press the first section of the barrier very firmly onto the flat surface to activate the self-adhesive layer (see Picture 4).

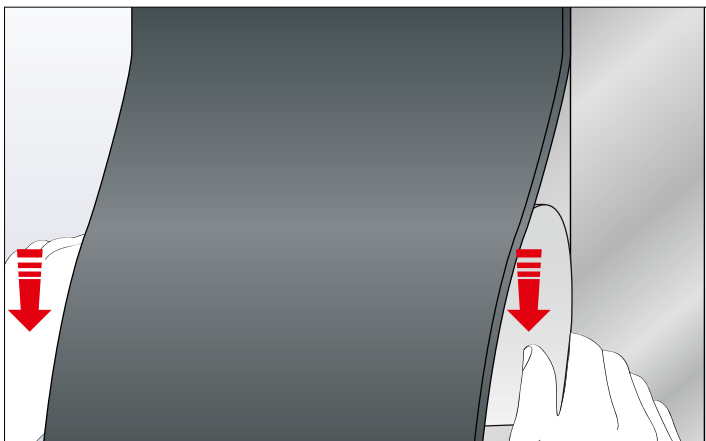

Picture 5

3.3) Continue to gradually peel back the protective foil and press ArmaComfort Barrier onto the application surface (see Picture 5).

WALL PARTITIONS

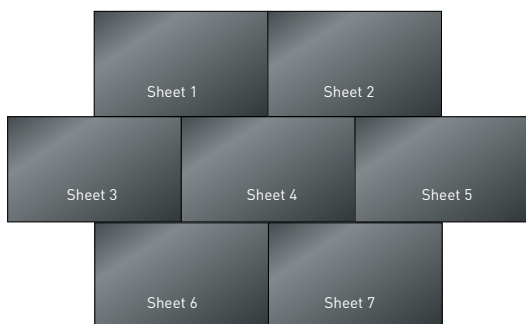

Picture 6

When applying ArmaComfort Barrier on large surfaces, always ensure that barrier joints are staggered (see Picture 6).

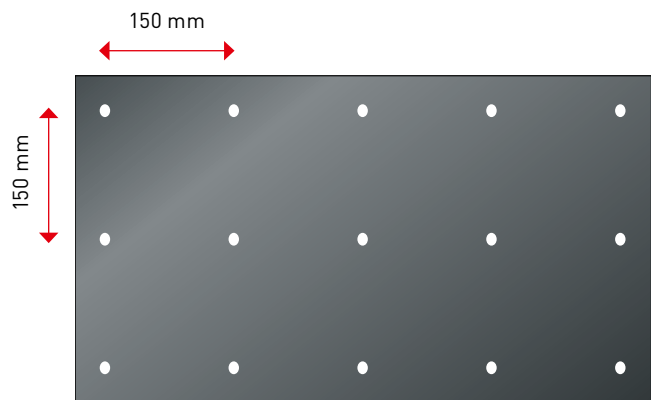

Picture 7

In order to strengthen the wall partition, screws with neoprene moulded seal are to be used every 150 mm vertically and horizontally (see Picture 7).

RECTANGULAR DUCTS

To prepare the installation of ArmaComfort Barrier B-Alu on square ducting, measure the height (b) and width (a) of the ducting using a tape measure or ruler.

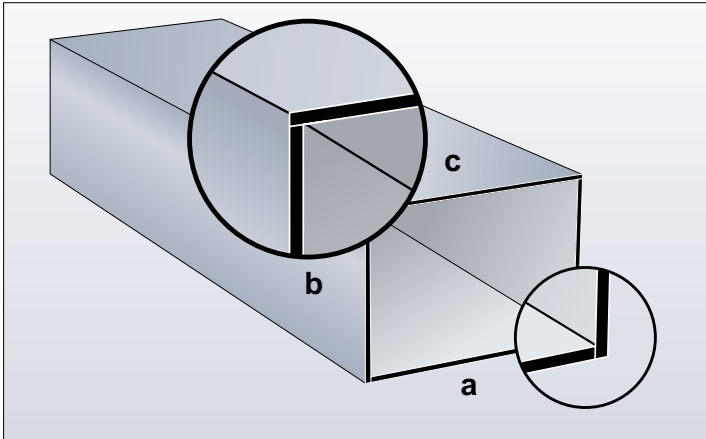

Picture 1

To ensure a neat joint the edges should be flush at the top and bottom. This is achieved by increasing the height (b) by adding one time the barrier thickness and increasing the width (c) by adding two times the barrier thickness. Transfer the height and width dimensions to the ArmaComfort Barrier B-Alu to be installed (see Picture 1).

a = width of duct
 b = height of duct + thickness of barrier
 c = width of duct + 2x thickness of barrier

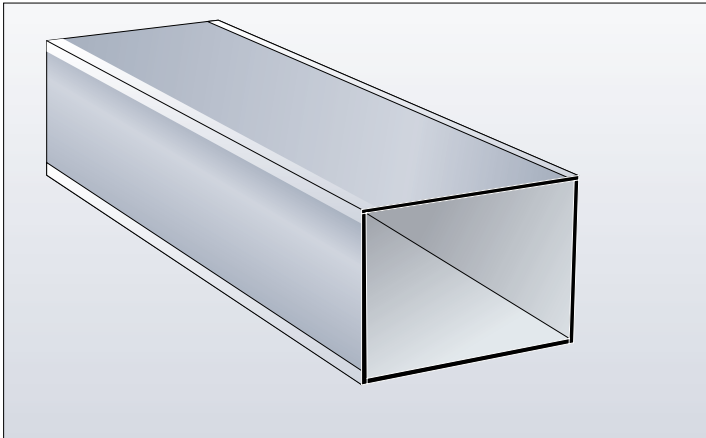

Picture 2

Apply ArmaComfort Barrier to the duct in the following order: a (bottom), b (left and right sides) and c (top). It is important that the pieces a, b and c are not longer than 1 m. The material should be applied as described in the section "Application on flat surfaces".

Apply alu tape to all seams to achieve a more professional finish (see picture 2).

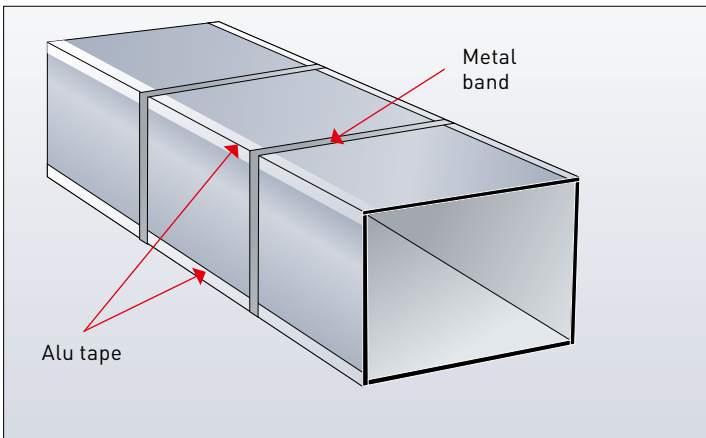

Picture 3

Note: It is recommended that a metal band is installed around the duct every 500 mm.

Angle irons can be used on the corners to prevent damage to the barrier surface (see picture 3).

ROUND DUCTS

ArmaComfort Barrier B-Alu with a thickness of 2 mm can be applied on round ducts with a minimum diameter of 60 mm. For round duct applications tape is mandatory on longitudinal seams and butt joints. When applying ArmaComfort Barrier on a round duct always use a strip of ArmaComfort Barrier to determine the circumference of the duct.



Picture 4

After installing the ArmaComfort Barrier B-Alu, apply aluminium tape on longitudinal seams and butt joints (see Picture 4).

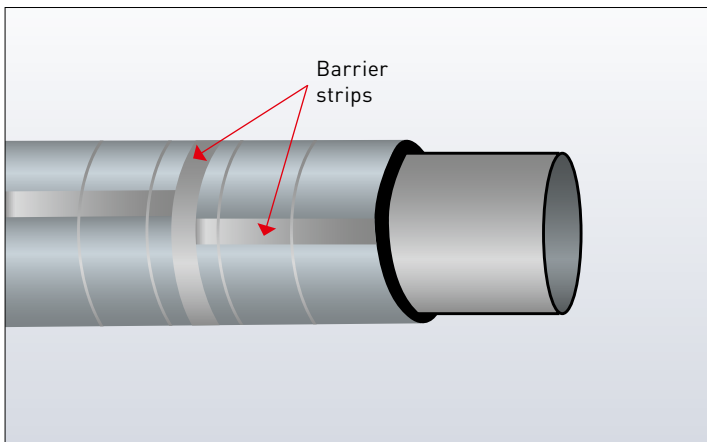

Picture 5

Application tips

To improve acoustic performance and avoid gaps on longitudinal seams and butt joints, apply 50 mm width ArmaComfort Barrier strip onto the seams. Then secure the strip edges using alu tape (see Picture 5).

Attention: Strips must be applied first to the butt joints, then to the longitudinal seams.

90° SEGMENTED BEND APPLICATION

FABRICATION EXAMPLE: 90° SEGMENTED BEND

A segmented bend/long radius elbow can be manufactured using 3 measurements:

- 1) Elbow centre radius, R , the distance from the centre of the pipe to the weld.
- 2) Circumference around outside of pipe, C_i , measured by wrapping a strip of ArmaComfort Barrier around the pipe.
- 3) d_i the outer diameter of the pipe.

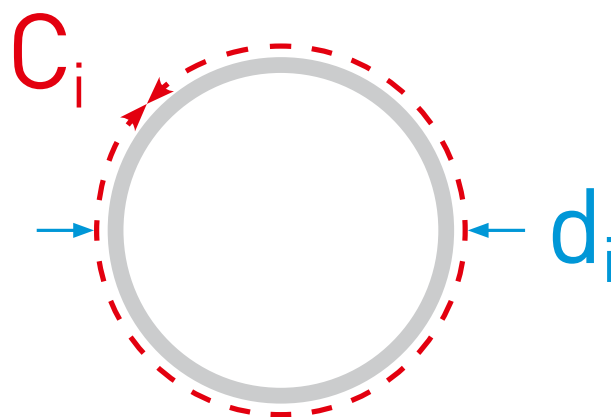
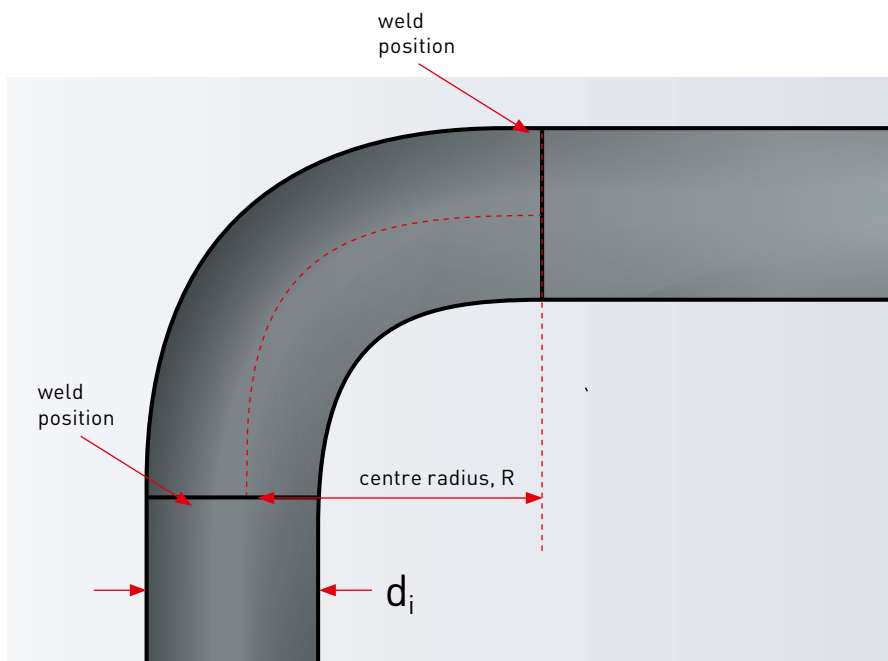
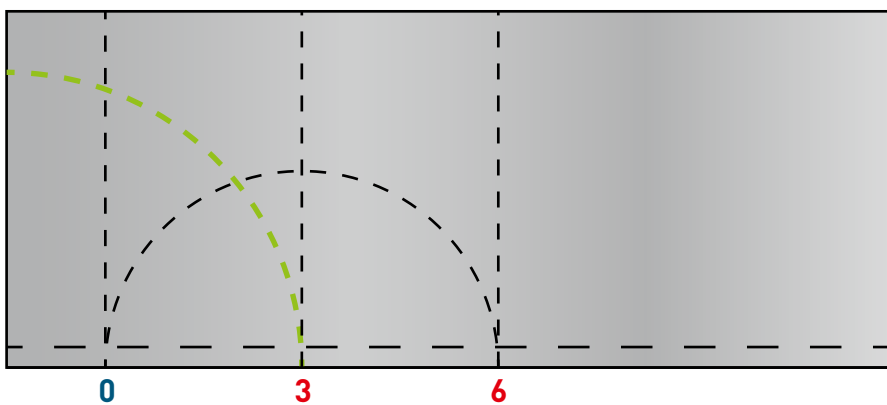
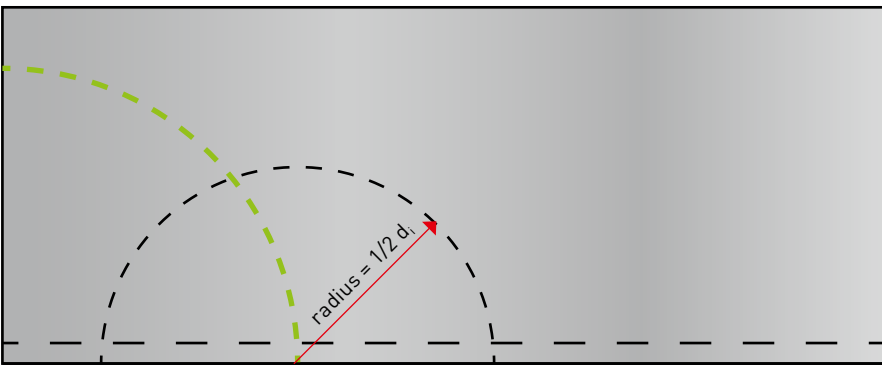
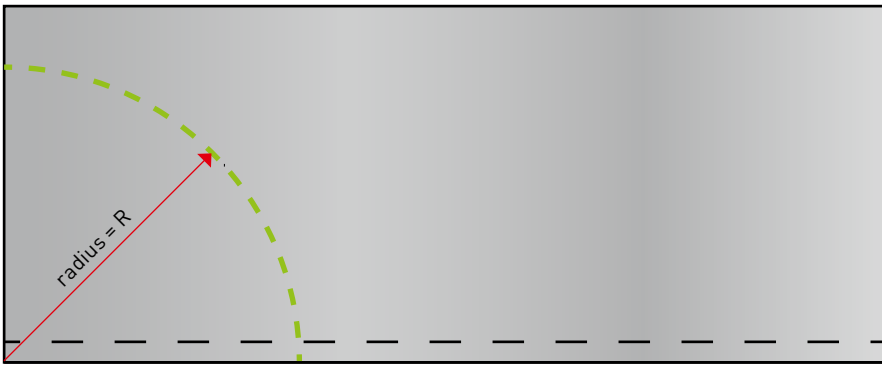
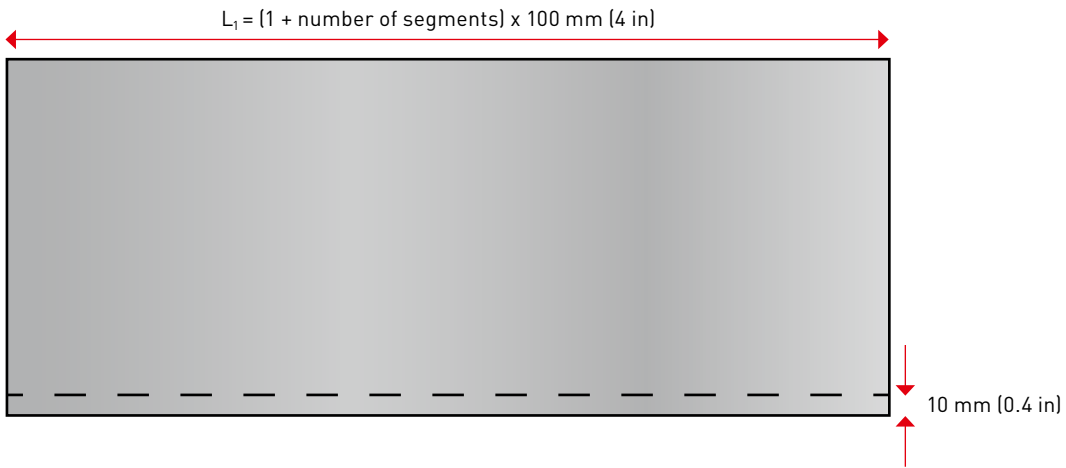

Table 1:
Determination of correct number of 90° bend segments

PIPE SIZE NB (in)	PIPE OD (mm)	CENTRE RADIUS (mm)	QUANTITY (#) OF SEGMENTS	L1 (mm) =100(#+1)
0.5	21.3	38	MITRE	
0.75	26.7	28.5	MITRE	
1	33.4	38	MITRE	
1.25	42.2	47.5	MITRE	
1.5	48.3	57	MITRE	
2	60.3	76	3	400
2.5	73	95	3	400
3	88.9	114	3	400
3.5	101.6	133	3	400
4	114.3	152	4	500
5	141.3	190	4	500
6	168.3	229	4	500
8	219.1	305	5	600
10	273.1	381	7	800
12	323.9	457	7	800
14	355.6	533	9	1000
16	406.4	610	9	1000
18	457	686	11	1200
20	508	762	11	1200
22	558.8	838.2	11	1200
24	610	914	13	1400
26	660.4	990.6	13	1400
28	711.2	1066.8	13	1400
30	762	1143	13	1400
32	812.8	1219.2	13	1400
34	863.6	1295.4	15	1600
36	914	1372	15	1600
38	965.2	1447.8	15	1600
40	1016	1524	15	1600
42	1066.8	1600.2	15	1600
44	1117.6	1676.4	17	1800
46	1168.4	1752.6	17	1800
48	1219.2	1828.8	17	1800
50	1270	1905	19	2000
52	1320.8	1981.2	19	2000
54	1371.6	2057.4	19	2000
56	1422.4	2133.6	21	2200
58	1473.2	2209.8	21	2200
60	1524	2286	21	2200
62	1574.8	2362.2	21	2200
64	1625.6	2438.4	23	2400
66	1676.4	2514.6	23	2400
68	1727.2	2590.8	23	2400
70	1778	2667	23	2400
72	1828.8	2743.2	23	2400

Consult the table on the left to determine the number of segments for a standard long-radius (R = 1.5 Ø) elbow.

In addition to the segments, 1 starter and 1 finisher piece are required.



Draw 3 vertical lines from the intersections of the curves with the base line. Label the lines 0, 3, 6.

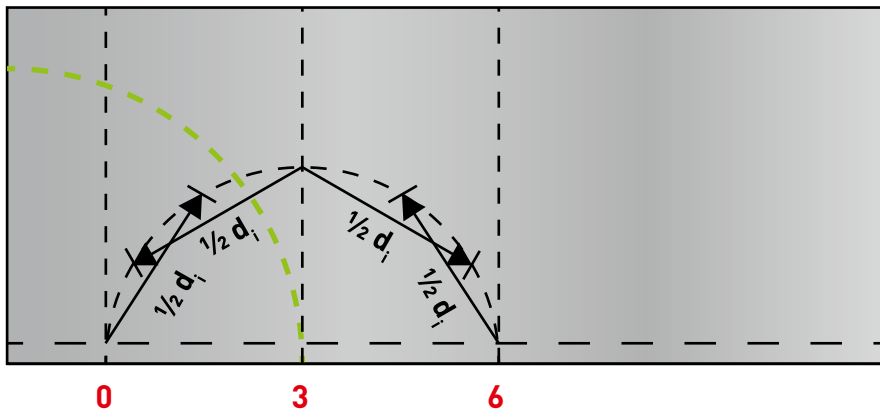

Draw 4 arcs of radius = $\frac{1}{2} d_i$ from the intersections of the vertical lines with the second curve, to intersect the second curve.

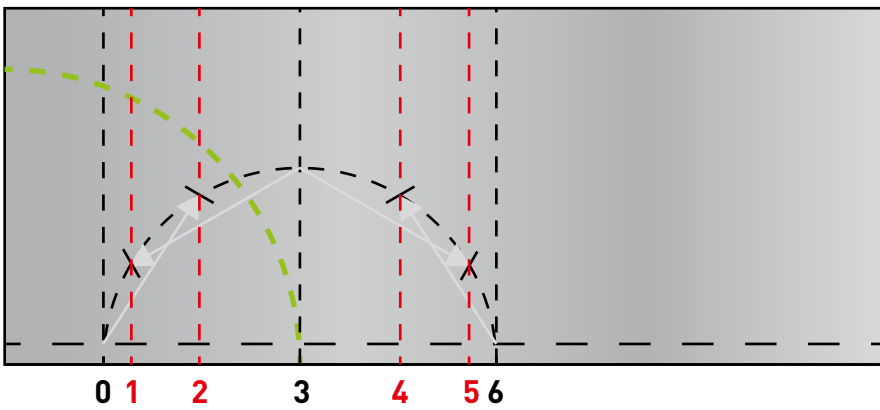

Draw 4 more vertical lines through the intersections of the arcs with the second curve. Label these vertical lines 1, 2, 4, 5.

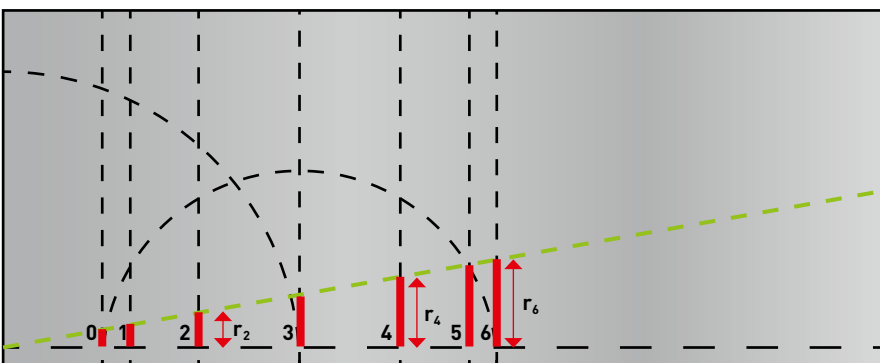
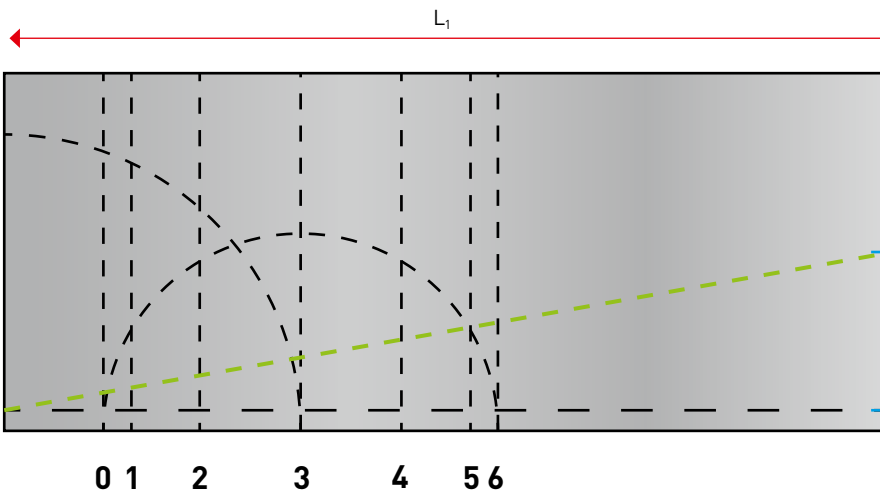

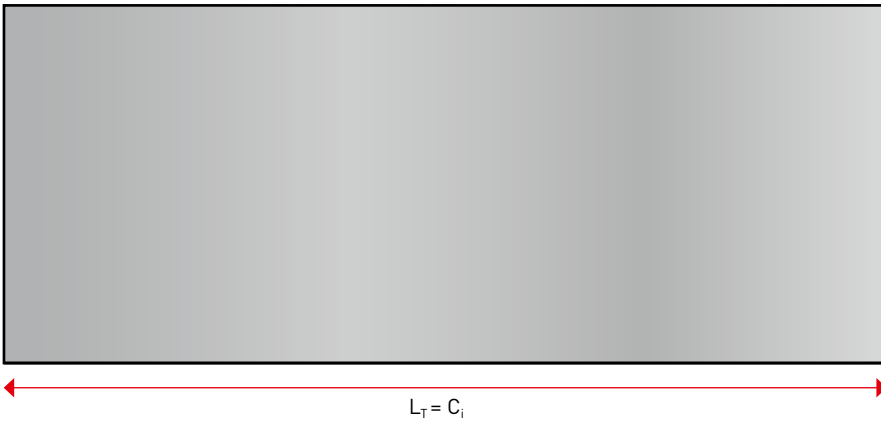

Use a new template and mark out the length L_T to equal the circumference C_i

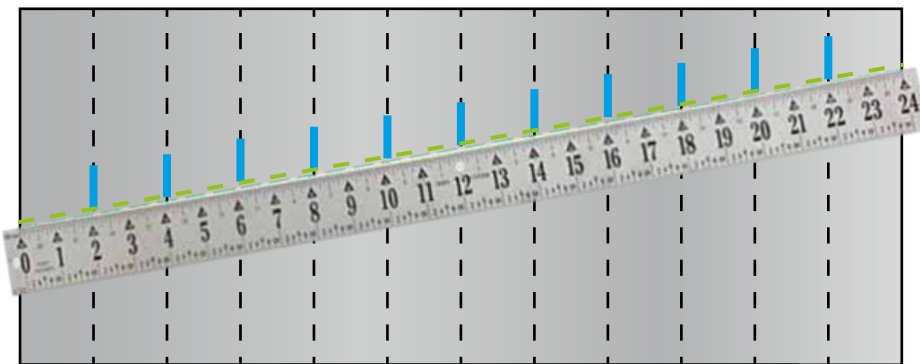

Draw a diagonal line of any length divisible by 12 and mark the line into 12 parts. Larger elbows may require division into 14 parts. Use these marks to draw vertical lines. This is a simple technique which makes dividing the template into equal parts much easier.

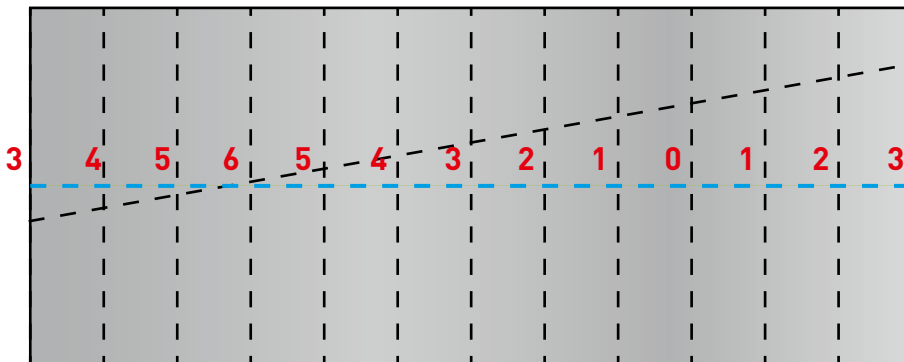

Draw a horizontal line in the centre and number the intersections as shown.

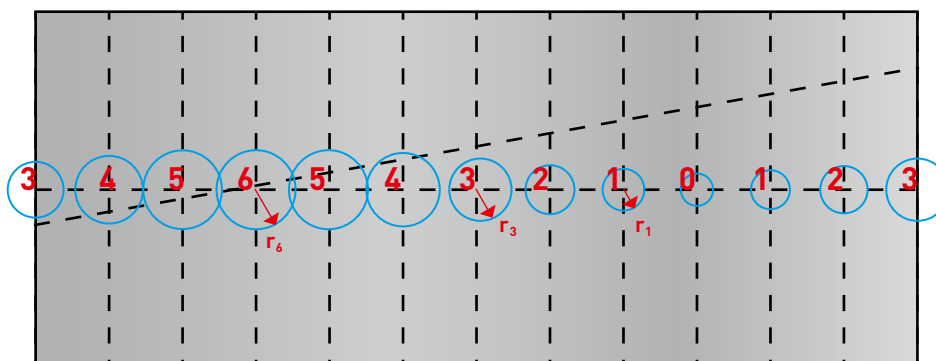

Draw circles using the length r_0 to r_6 from the previous template as the radii of circles. Centre the circles on the intersections of the horizontal line with the numbered vertical lines.

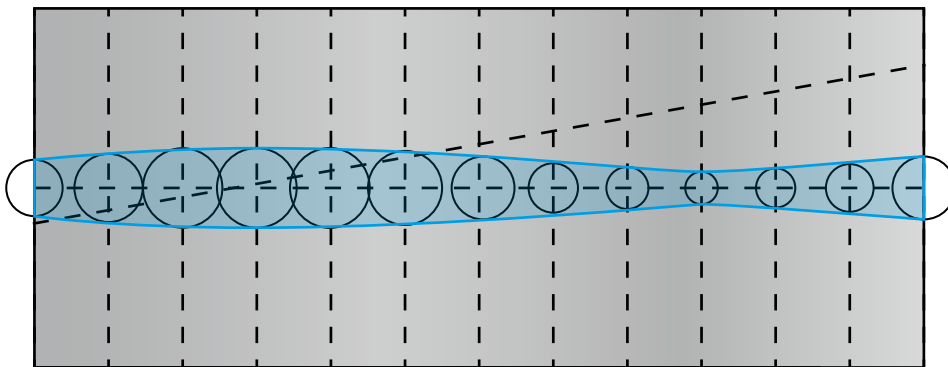

Draw smooth lines to join the circles.

Segment template

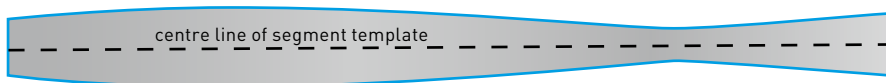

Cut out the segment template

Starter/finisher template

100 mm
(4 in)

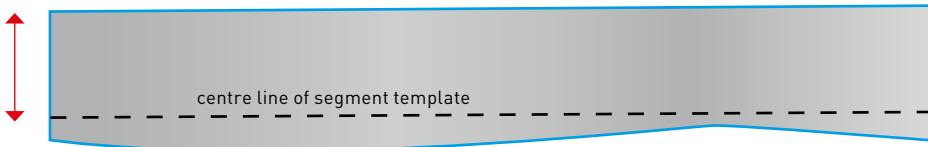

Create starter/finisher template by adding 100 mm (4 in) to half of a segment piece

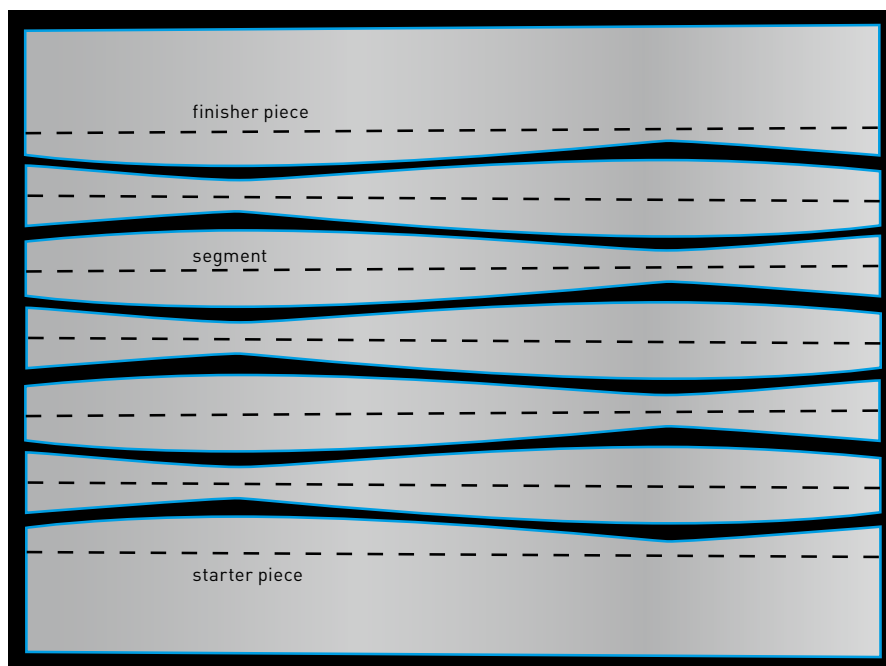

Use the template to mark out ArmaComfort Barrier with a starter piece, the appropriate number of segments and a finisher piece.

T-PIECE APPLICATION

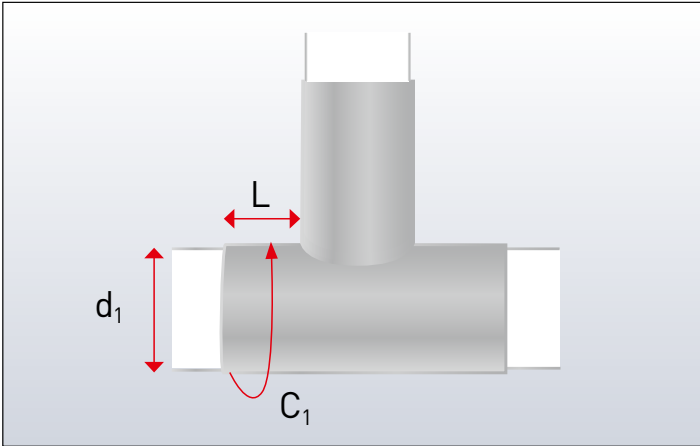

Measure the circumference C_1 and the diameter d_1 of the pipe.

Use these measurements to create a template for marking out how to cut the ArmaComfort Barrier

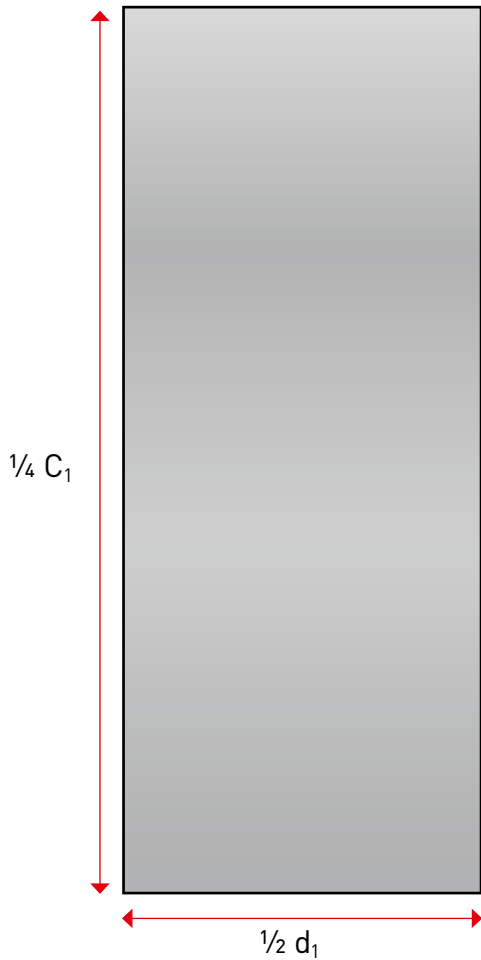

Cut a rectangular template, length = $\frac{1}{4} c$, height = $\frac{1}{2} d_1$

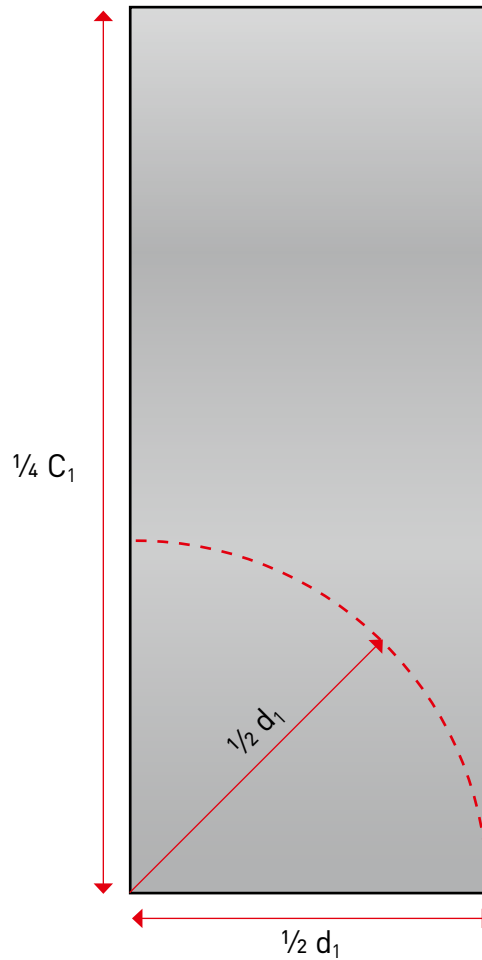

Draw an arc, radius = $\frac{1}{2} d_1$

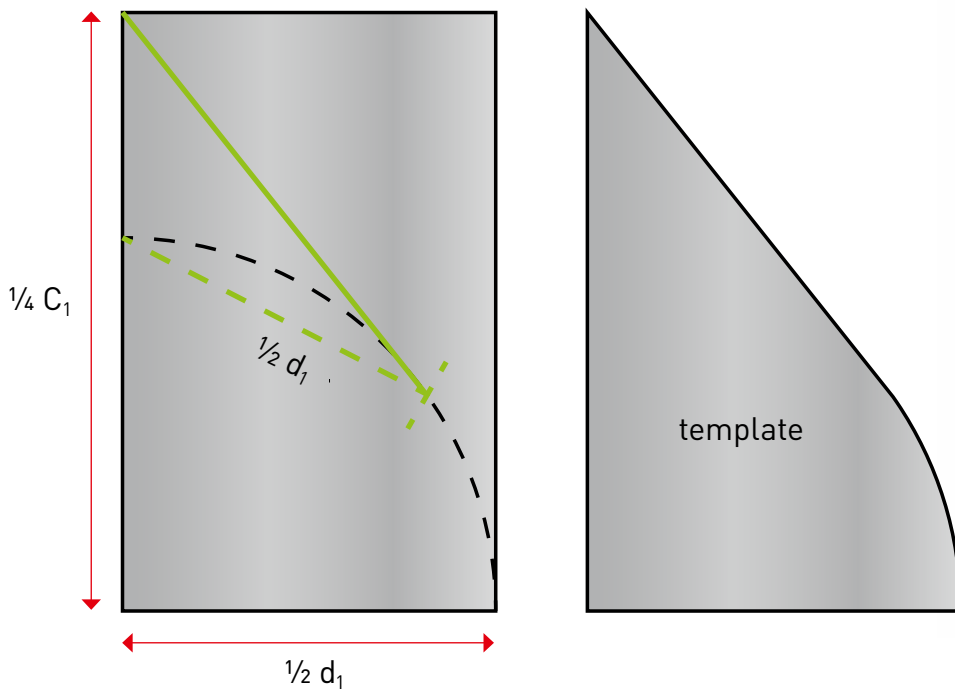

Taking the left-hand side of the original arc as the origin, mark a distance $\frac{1}{2} d_1$ along the original arc. Draw a line from the intersection to the top corner and cut the template as shown.

Use template to mark out two sheets of ArmaComfort Barrier, as shown below.

L = desired leg lengths of T-piece (typically > 50 mm (2 in)).

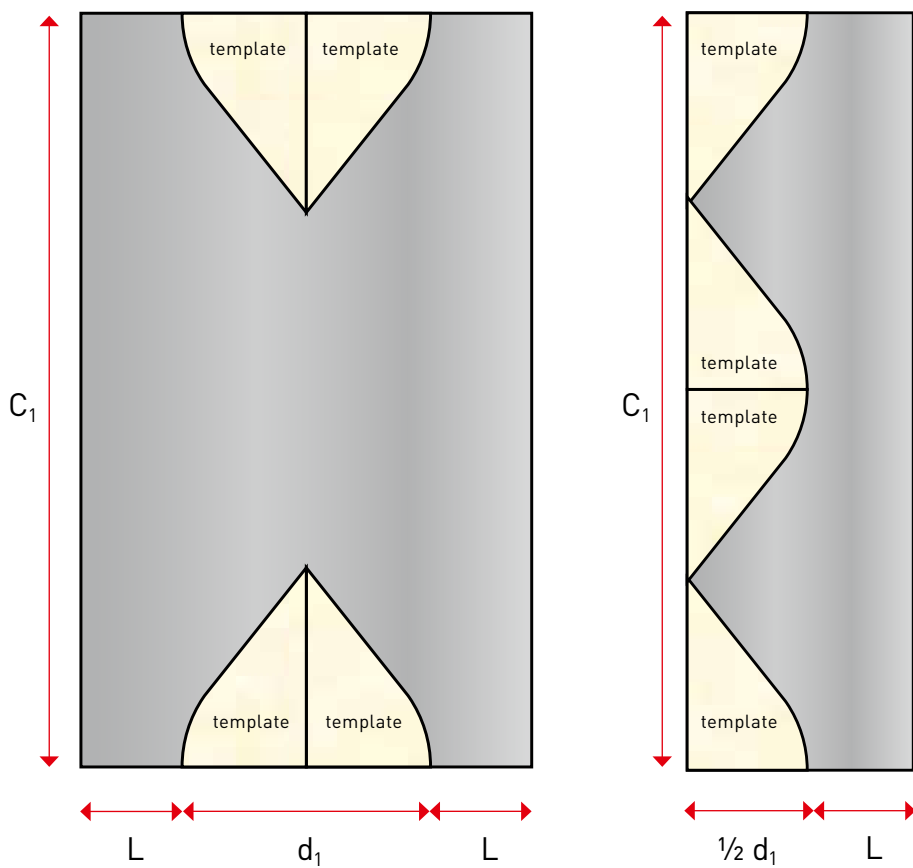

CEILING PLENUMS

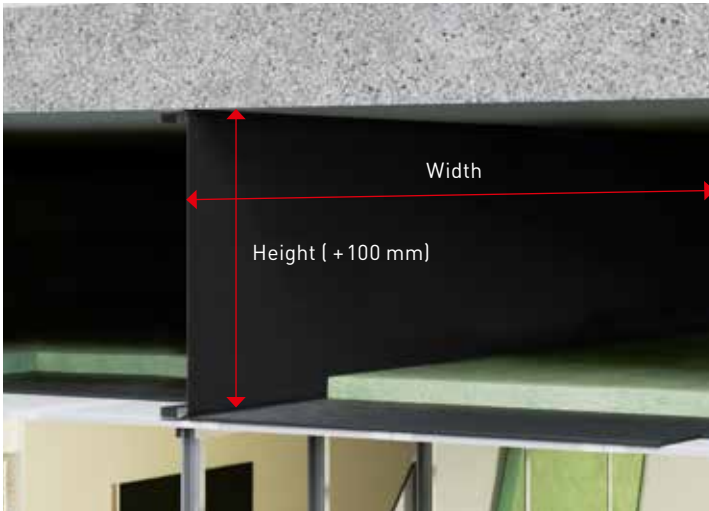

Picture 1

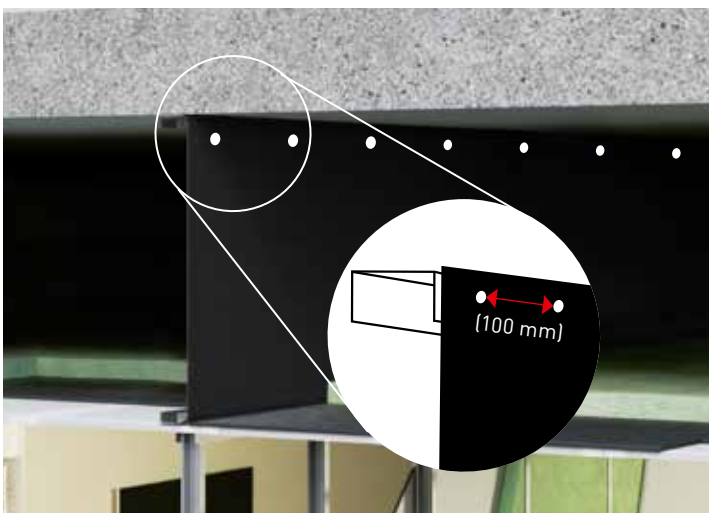

Picture 2



Picture 3

1) Before cutting ArmaComfort Barrier, be sure to measure the dimensions of the ceiling (height, width) accurately and transfer them onto the ArmaComfort Barrier. Add 100 mm to the height of the barrier so that it can be adhered to the floor.

2) ArmaComfort Barrier B-Alu to be attached to the U-profile (used for plasterboard) using screws. To prevent damage to the surface of the barrier, screws with neoprene moulded seals are recommended. The distance between the screws should be 100 mm.

3) The barrier is adhered to the floor with a 100 mm adhesive surface. Bonding should not be carried out under tensile force.

Note: Local fire regulations (e.g. firewalls) have to be observed.



All data and technical information are based on results achieved under the specific conditions defined according to the testing standards referenced. Despite taking every precaution to ensure that said data and technical information are up to date, Armacell does not make any representation or warranty, express or implied, as to the accuracy, content or completeness of said data and technical information. Armacell also does not assume any liability towards any person resulting from the use of said data or technical information. Armacell reserves the right to revoke, modify or amend this document at any moment. It is the customer's responsibility to verify if the product is suitable for the intended application. The responsibility for professional and correct installation and compliance with relevant building regulations lies with the customer. This document does not constitute nor is part of a legal offer to sell or to contract.

At Armacell, your trust means everything to us, so we want to let you know your rights and make it easier for you to understand what information we collect and why we collect it. If you would like to find out about our processing of your data, please visit our [Data Protection Policy](#).

© Armacell, 2020. All trademarks followed by ® or ™ are trademarks of the Armacell Group.
00442 | ArmaComfort Barrier | ArmaComfort | Manual | 112020 | EMEA | EN MASTER

ABOUT ARMACELL

As the inventors of flexible foam for equipment insulation and a leading provider of engineered foams, Armacell develops innovative and safe thermal, acoustic and mechanical solutions that create sustainable value for its customers. Armacell's products significantly contribute to global energy efficiency making a difference around the world every day. With 3,135 employees and 24 production plants in 16 countries, the company operates two main businesses, Advanced Insulation and Engineered Foams. Armacell focuses on insulation materials for technical equipment, high-performance foams for high-tech and lightweight applications and next generation aerogel blanket technology. For more information, please visit: www.armacell.com.

For product information, please visit:
www.armacell.eu

